



Built-in central vacuum unit

**So small,
yet so perfect**



www.sistemair.com



Think big, install the best

Wolly, the unquestioned King of built-in central vacuum units, has received a makeover. It's been updated, in order to make it easier than ever to install, to make it run even more silently and to make it suitable for even more applications.

The result is a product with fantastic built quality, designed to become standard equipment for all houses, even in homes where space is at a premium.

ESPECIALLY
FOR MULTI
STOREY
BUILDINGS

Central vacuum units suitable for installation in small apartments and residential units typically found in multi storey buildings.





The central vacuum system...

- Guarantees hygiene in your home, because it expels micro dust outside, together with mites and pollens not captured by the filter.
- You can now clean your home in virtual silence, because the main motor has been almost completely soundproofed. The suction unit can be placed in an out of the way location (under the stairs, in a plantroom, etc...).
- It is totally safe, because the cleaning inlet valves contain low voltage contacts, devoid of risks.
- You can enjoy the comfort in cleaning. You can forget the traditional vacuum cleaner, heavy to transport and awkward to use; now you have only an easy and light flexible hose.
- It comes complete with a wide range of cleaning accessories, perfect for all situations.



Central vacuum system = energy saving

Sometimes, when cleaning your house you have to open a window to clear the air: if you do this on a cold day you waste a lot of heat and energy. The central vacuum system expels all vacuumed air outside; no need to open that window. It can be installed in any form of construction; Traditional Block Build, Timber Frame, ICF, Passive Homes etc.

Therefore, the energetic efficiency is more respect to a traditional vacuum cleaner, because the filter is separated to the dust container, in order to maintain its filtering capacity longer.

Wolly 2 – wall hang solution



Wolly 2 – built-in solution

Easy to install



Wolly 2, has become even easier to install: first fix of the pipe work and vacuum unit location can be done in few hours. Second fix is a very simple procedure too. Example: to install in an 80 m² apartment with two cleaning inlet valves, takes only 4 hours labour.

Beautiful to see

Elegant and simple, Wolly 2 has an elegant and modern design. It will blend in easily wherever installed. It is possible to conceal it behind a picture or painting or the front cover can be painted to blend in with the wall.



Wolly 2: technology



Connection to the piping system from either side, right or left



Vacuum breaker to reduce the motor effort



Soft Start device to reduce motor consumption during start up



Filter cartridge with advanced technology (12 l capacity) and security filter in polyester washable with water



The air exhaust can be connected from either side, right or left or from the front of the unit



It can be used with pipes of \varnothing 40 and 50 mm / 2"



Art. 7102.1 – Wolly 2 built-in case for pre-installation



Polystyrene shell with anti vibration function, sound absorbent and thermo insulating



Hook to fix the built-in case to the wall



Low over-hang profile



Art. 7102.2 – Wolly 2 pre-installation external case



Additional absorbent materials on the external case and hose indicating the connection to the house pipe through PVC sleeve



N.B.: to install wall hang solution Wolly 2 is necessary to combine the built-in case to the external case, art. 7102.1

Wolly 2: components used for the installation to the wall

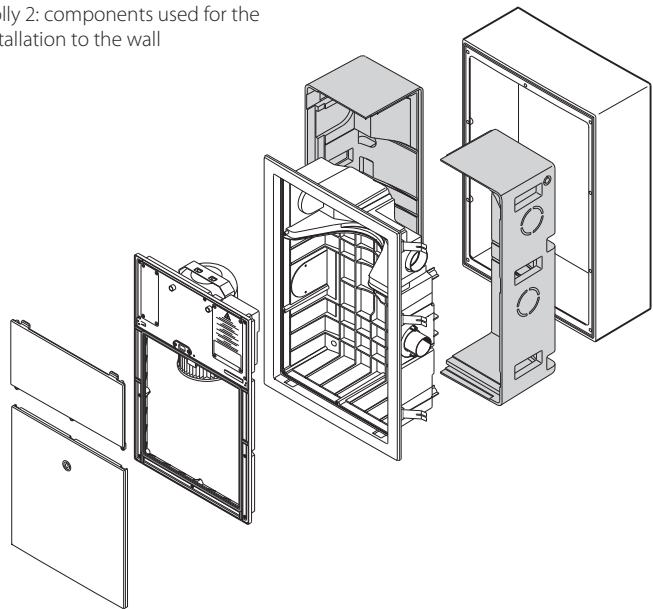

Dimensions

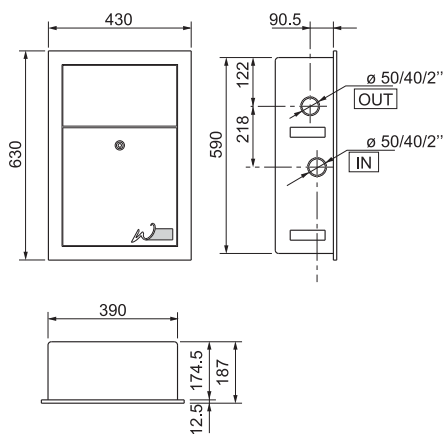



Technical features



Accessory cleaning kit
(Provided only with the central vacuum units art. 8201.0 and 8201.1)



		Wolly2 150	Wolly2 300
			
		art. 8201.0	art. 8201.1
Max operators	N°	1	1
Max surface	m ²	150	300
Max inlets	N°	4	7
Power supply	V ac	220/240	220/240
Frequency	Hz	50/60	50/60
Motor power	kW	1,3	1,4
Absorption	A	5,6	6,5
Max pressure drop	mmH ₂ O	2700	2900
Max air flow	m ³ /h	170	175
Inlets supply	V dc	12	12
Safety filter	cm ²	2840	2840
Dust bag capacity	lt	12	12
Weight	kg	9	9
Width	mm	430	430
Height	mm	630	630
Depth	mm	187	187
Inlet connection	ø mm	40/50/2"	40/50/2"
Exhaust connection	ø mm	40/50/2"	40/50/2"



Art. 8202.0
Motor module Wolly 2 mod. 150

Art. 8202.1
Motor module Wolly 2 mod. 300

